

# **ds** DATA SCALE

**AUTOMATED LIQUID FILLING SYSTEMS**

42430 Blacow Road, Fremont, CA 94539  
(510) 651-7350 [www.DataScale.com](http://www.DataScale.com)

# Model 504 Filler Series

*Modular systems combine to create a custom solution*

- **Pneumatic Requirements:** 80 to 100 P.S.I. – 3 C.F.M Customization . @ 35 to 105 degrees F
- **Container Size** 1 to 7 gallon open top pails, Square, and Round Pails, Jerry Cans, Cartons, and Boxes.
- **Output** 8 to 18 per minute  
Optional 1 Gallon Feature



**Four head automatic net weight filler solution for filling multiple containers simultaneously**

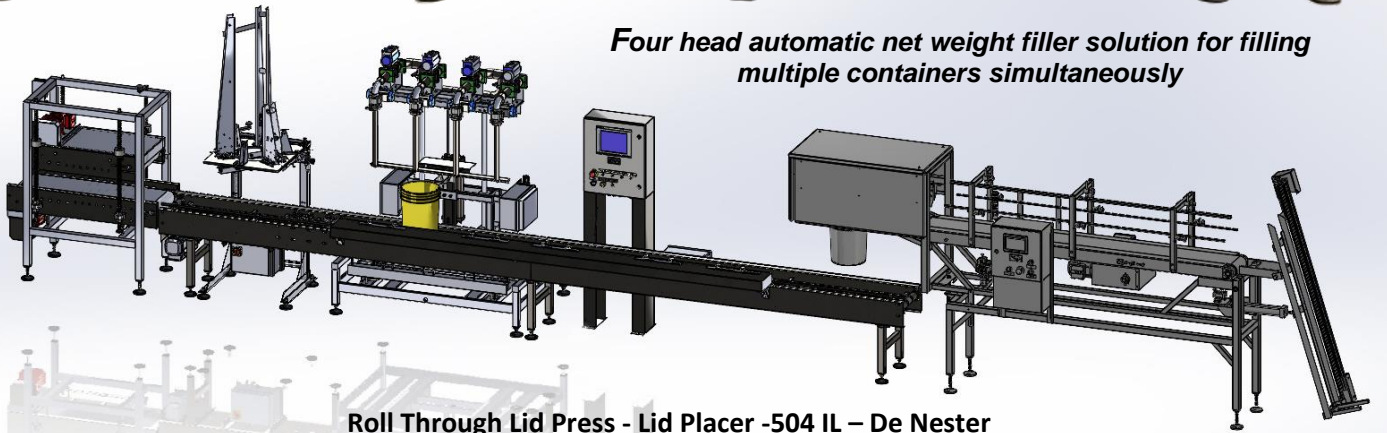

**Roll Through Lid Press - Lid Placer -504 IL – De Nester**

Fully Automated System For all Types of Products and Containers

check out our Web Site for more information on our filling solutions <https://www.Datascale.com/>

## Available Options

- Intelligent Industrial designs made to last
- Automatic Container Handling
- Wetted Parts Options
- Explosion Proof Package
- Fume Hood
- Pump Control
- Support for multiple size containers
- Stainless Steel Control box
- Available in Fixed Sub Surface and Top surface to Meet any filling Requirements
- Food Grade Features & Options All stainless steel construction, CIP (including quick change spare manifold), Teflon seals including ball valves and wash-down motors & pneumatics.
- Auto Indexing System
- Customization



Data Scale is a winner of the prestigious Vaaler Award, given by the Chemical Processing Industry, for innovative product design.



PMMI members are globally renowned for making the highest quality equipment, offering responsive service and committing to meeting their customers' needs. That is why one out of every four machines sold around the world is made by a PMMI member company

Since 1973, Data Scale has been the industry leader in liquid net weight filling equipment for food and chemical industries. Data Scale is the oldest continually owned and operated manufacturer of liquid net weight drum & pail filling equipment in North America. Data Scale can provide application system integration, providing innovative real-world solutions for your liquid filling and automation needs.



42430 Blacow Road, Fremont, CA 94539  
 (510) 651-7350 [www.DataScale.com](http://www.DataScale.com)

# Model 504 Filler Series

## 504-IL

- Quad lance
- Net weight filler for liquids
- Supports boxes, Jugs, and open head containers
- Allen Bradley PLC and HMI

- **Pneumatic Requirements:** 80 to 100 P.S.I. – 3 C.F.M
- Customization**  
 . @ 35 to 105 degrees F
- Container Size** 1 to 7 gallon open top pails, Square, and Round Pails, Jerry Cans, Cartons, and Boxes.
- Output** 8 to 18 per minute
- Optional 1 Gallon Feature

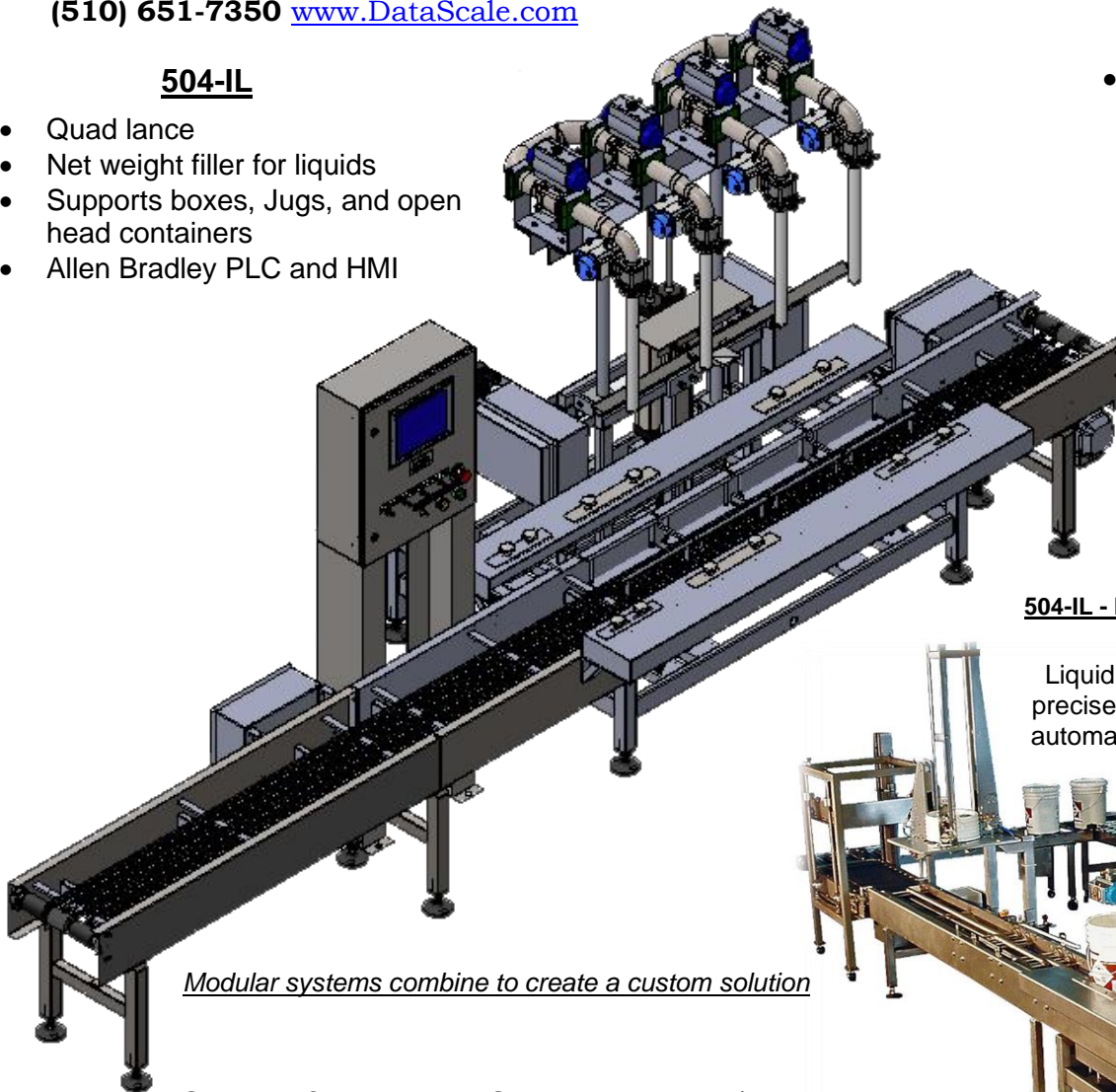

*Modular systems combine to create a custom solution*

## 504-IL - Lid Placer – Roll Through Lid Press (RTLPL)

Liquid filling equipment featuring precise net weight control and fully automatic operation without waste.

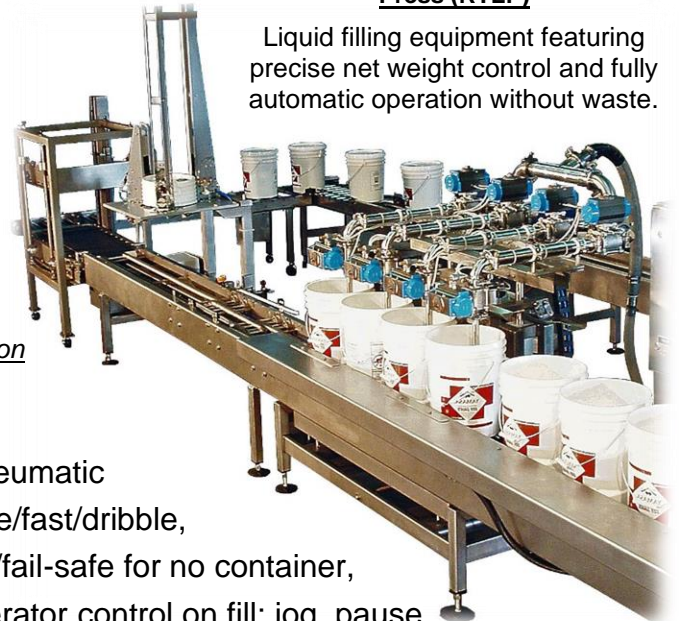

Controls feature Data Scale's electronic/pneumatic control console and automatic filling program with dribble/fast/dribble, auto tare, operator prompting/fill status, serial I/O, no fill/fail-safe for no container, lance misalignment, and lance down interlock. Also operator control on fill; jog, pause, about, flush, and emergency stop. Mechanism features one-piece frame with height adjustment for scales and fill head. Fail-safe for lance down and misalignment. Includes; 316 stainless steel lances and manifold assembly with Teflon seat full port ball valves, air to air actuators, spring close fail-safe, and adjustable rate dribble. Lower assembly and automatic drip catcher. Scale features 12" by 12" 100 Lb. Capacity and 100% overload. Calibrated to 100 Lb. by 0.01 Lb. Meets NTEP class III requirement.



Data Scale is a winner of the prestigious Vaaler Award, given by the Chemical Processing Industry, for innovative product design.



PMMI members are globally renowned for making the highest quality equipment, offering responsive service and committing to meeting their customers' needs. That is why one out of every four machines sold around the world is made by a PMMI member company

Since 1973, Data Scale has been the industry leader in liquid net weight filling equipment for food and chemical industries. Data Scale is the oldest continually owned and operated manufacturer of liquid net weight drum & pail filling equipment in North America. Data Scale can provide application system integration, providing innovative real-world solutions for your liquid filling and automation needs.