

Semi-Automatic Lid Press

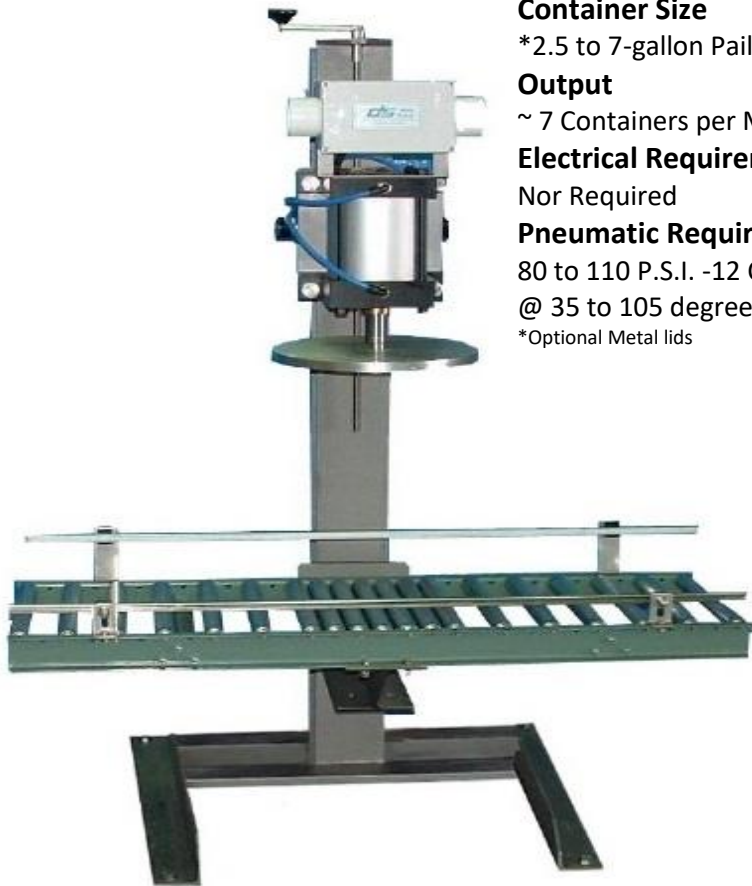

Semi-Auto Press (SALP)

- 7 Presses / Min
- Pails- Plastic / Metal

Container Size

*2.5 to 7-gallon Pails

Output

~ 7 Containers per Minute

Electrical Requirements

Nor Required

Pneumatic Requirements

80 to 110 P.S.I. -12 C.F.M.

@ 35 to 105 degrees F

*Optional Metal lids



501-S Semi-Auto Press (SALP) on Portable Cart

Available Options

- Stainless Steel Upgrade
- Portable Cart System



- Crimper Head

Semi-Automatic Lid Press

- **Dimension:** 48" L x 24" W x 63" H
- **Conveyor Size:** 48" L x 11" W
- **Description:** Manual positioning and activation with two-hand safety controls. Includes height adjustment, floor stand, air filter regulator and 48" gravity conveyor.



Data Scale is a winner of the prestigious Vaaler Award, given by the Chemical Processing Industry, for innovative product design.



Leading companies.
 Leading solutions.

PMMI members are globally renowned for making the highest quality equipment, offering responsive service and committing to meeting their customers' needs. That is why one out of every four machines sold around the world is made by a PMMI member company

Since 1973, Data Scale has been the industry leader in liquid net weight filling equipment for food and chemical industries. Data Scale is the oldest continually owned and operated manufacturer of liquid net weight drum & pail filling equipment in North America. Data Scale can provide application system integration, providing innovative real-world solutions for your liquid filling and automation needs.

Automatic Lid Press



Automatic Lid Press (ALP)

- 20 Presses / Min
- Pails- Plastic / Metal

Container Size

*2.5 to 7-gallon Pails

Output

Up to 20 Containers per Minute

Electrical Requirements

230/460 VAC 3 Phase

Pneumatic Requirements

80 to 110 P.S.I. -12 C.F.M.

@ 35 to 105 degrees F

*Optional Metal lids



Lid Placer Automatic Lid Press (ALP)

Available Options

- Stainless Steel Upgrade
- Portable Cart System



- Crimper Head

Automatic Lid Press

- **Dimension:** 48" L x 30" W x 66" H
- **Conveyor Size:** 48" L x 11" W
- **Description:** Automatically seals pre-placed lids onto pails. Includes height adjustment, floor stand, air filter regulator and 48" gravity conveyor.



Data Scale is a winner of the prestigious Vaaler Award, given by the Chemical Processing Industry, for innovative product design.

MEMBER



Leading companies.
Leading solutions.

PMMI members are globally renowned for making the highest quality equipment, offering responsive service and committing to meeting their customers' needs. That is why one out of every four machines sold around the world is made by a PMMI member company

Since 1973, Data Scale has been the industry leader in liquid net weight filling equipment for food and chemical industries. Data Scale is the oldest continually owned and operated manufacturer of liquid net weight drum & pail filling equipment in North America. Data Scale can provide application system integration, providing innovative real-world solutions for your liquid filling and automation needs.

RTLP

Roll Through Lid Press

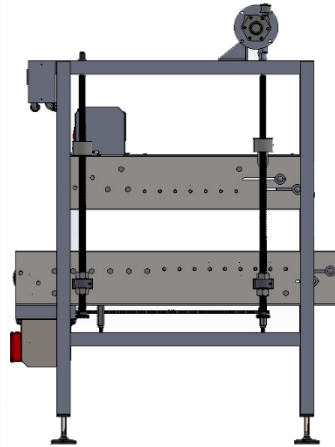
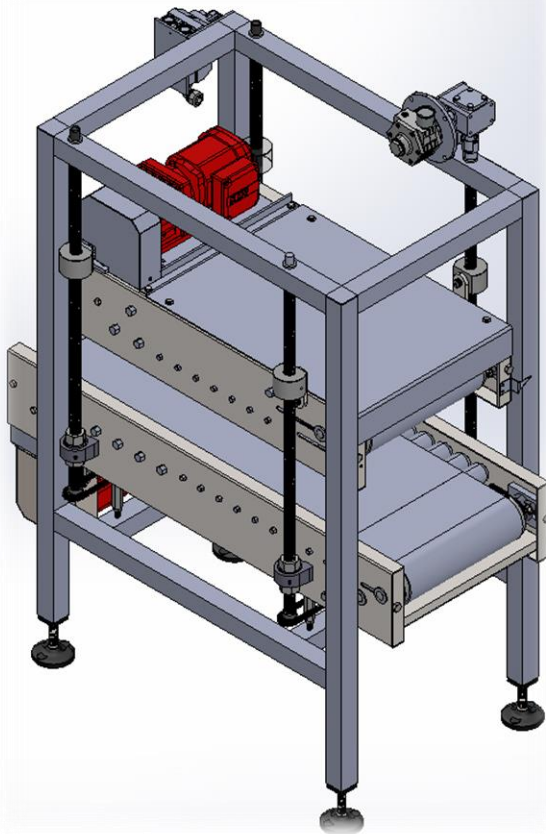

Container Size

*2.5 to 6.5-gallon Pails

Output

Up to 70 Containers per Minute

Electrical Requirements

230/460 VAC 3 Phase

Pneumatic Requirements

80 to 110 P.S.I. -12 C.F.M.

@ 35 to 105 degrees F

*Optional Metal lids

Available Options

- Stainless Steel Upgrade
- Multiple Container Support
- Air motor height adjust

Roll Through Lid Press (RTLP)

- 70 Presses / Min
- Pails- Plastic

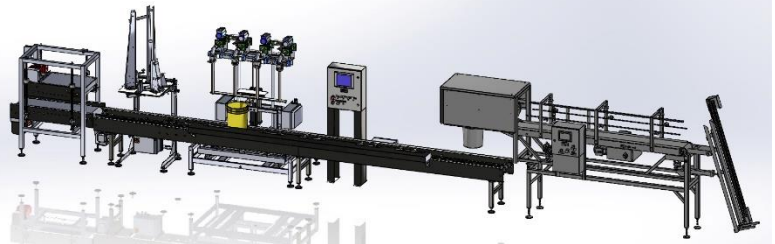

Roll Through Lid Press - Lid Placer -504 IL – De Nester

Fully Automated System For all Types of Products and Containers
 Feel Free to check out our Web Site for more information on our
 filling solutions <https://www.datascale.com/>

Roll Through Lid Press

- **Dimension:** 48" L x 24" W x 54" H
- **Conveyor Size:** 48" L x 14" W
- **Description:** Automatically press pre-placed lids onto pails • 70 pails per minute maximum • Stainless Steel construction available • Dual Motor Drives • Single adjustment handle with one inch diameter Acme rods • Hand crank can be positioned on any corner • Stainless Steel Drive Pulleys are made with a special surface treatment for grip and tracking • Easy access belt tension • Floor stand with adjustable height legs • 220 VAC @ 3 AMPS



Data Scale is a winner of the prestigious Vaaler Award, given by the Chemical Processing Industry, for innovative product design.



Leading companies.
 Leading solutions.

PMMI members are globally renowned for making the highest quality equipment, offering responsive service and committing to meeting their customers' needs. That is why one out of every four machines sold around the world is made by a PMMI member company

Since 1973, Data Scale has been the industry leader in liquid net weight filling equipment for food and chemical industries. Data Scale is the oldest continually owned and operated manufacturer of liquid net weight drum & pail filling equipment in North America. Data Scale can provide application system integration, providing innovative real-world solutions for your liquid filling and automation needs.